

STANDARD VISION PANEL

VT's standard vision panel will be Model 110, low profile fire door light frame, from All Metal Stamping. Other vision panels may be specified and used, but in the event no model is specified, the 110 will be used.

Increasing interest in low profile vision panels has brought about this change. The vision panel meets UL10B requirements for negative pressure plus UL10C requirements for positive pressure.

Properties:

- 18 gauge CRS frame is standard (33% thicker than 20 gauge frames)
- Beige polyester powder coating
- Standard frame fits 1/4" glass and 1-3/4" door
- Special frame sizes available to accommodate a variety of glass and door thickness
- No glazing compound, tape or intumescent is required for most label applications.
- Low profile provides less interference with exit hardware
- Welded stiffener reduces corner flex Exclusive nail-in fastening method:
- Requires only one person to install
- Significantly reduces installation time
- Corridor side is fastener free, secure and attractive

Exclusive nail-in fastening method:

- Requires only one person to install
- Significantly reduces installation time
- Corridor side is fastener free, secure and attractive

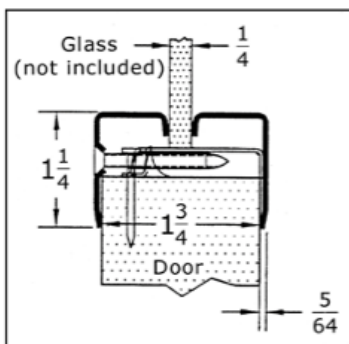
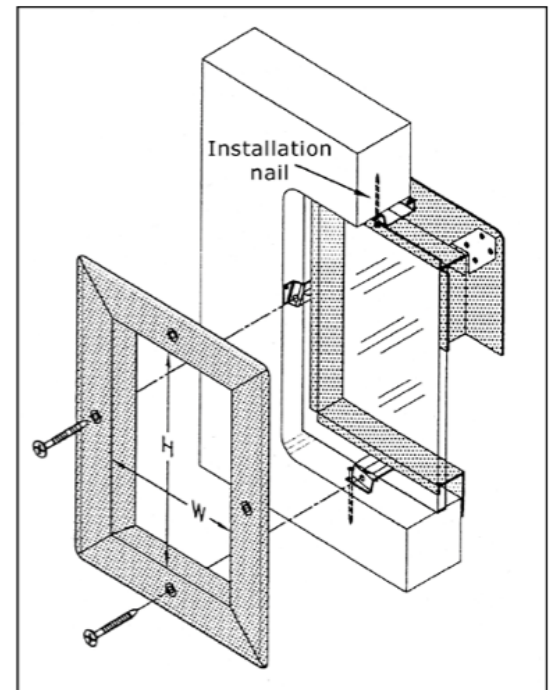

Available Options:

- Special colors
- Wood veneer wrapped
- 18 gauge stainless steel for hospital or food service
- Special glass thickness
- Special door thickness